

65M



JXRZ 65-5.20



GENERAL

PIPE SIZE (ID)	125 mm (5")
BOOM CONTROL VALVE	Proportional (by HAWE)
RADIO REMOTE	Dual Wireless Transmitter System
VIBRATOR	Standard
WATER PUMP	Hydraulic Power 20 bar (290 psi)
WATER TANK	800 L (211 G)
WEAR PARTS	Carbide
POPULAR UPGRADES†	<ul style="list-style-type: none"> • LED Boom Light Kit • LED Outrigger Lights • Heated Water Tank • Heated Hydraulic Tank • Air-Cuff • Twin Wall Pipe • 20 cell Pump Kit • CCI lined backend

BOOM

NUMBER OF BOOMS	5 Sections
FOLDING TYPE	RZ Fold
VERTICAL HEIGHT	64.5 m (211'7")
HORIZONTAL REACH	59.6 m (195'6")
UNFOLDING HEIGHT	17 m (55'9")
1ST SECTION	13.25 m (43'6")
2ND SECTION	10.75 m (35'3")
3RD SECTION	10.5 m (34'5")
4TH SECTION	12.9 m (42'4")
5TH SECTION	13 m (42'8")
OUTRIGGER	X-Style
FRONT SPREAD	12.65 m (41'6")
REAR SPREAD	12.3 m (40'4")

†More options available, ask your sales rep for details.

PUMP

OUTPUT:	Rod Side	181 m³/h (235 yd³/h)
	Piston Side	122 m³/h (159 yd³/h)
PRESSURE:	Rod Side	85 bar (1233 psi)
	Piston Side	130[†] bar (1886 psi)
CONCRETE CYLINDER DIAMETER	230 mm (9")	
CONCRETE CYLINDER TYPE	Hard Chromed	
STROKE LENGTH	2100 mm (83")	
S-TUBE SIZE	9" x 7"	
MAIN OIL PUMP	Twin Rexroth Hydromatic A20VLO190	
HYDRAULIC SYSTEM PRESSURE	350 bar (5076 psi)	
LUBE SYSTEM (HOPPER)	Automatic	
SWITCHING SYSTEM	Hydraulic	
HOPPER CAPACITY	Easy Clean 600 L (158 G)	
NUMBER OF STROKES/MIN	34	
OUTPUT CONTROL RANGE	20(26)-181m³ (235yd³/h)	

†Not to be used through boom pipe

Alliance Concrete Pumps Inc. reserves the right to make changes to all specifications

ALLIANCECONCRETEPUMPS.COM



USA OFFICE: 800 West Ridge Road, Linwood, PA 19061
Toll Free 1.888.584.7231 | Phone 610.584.7231 | Fax 610.584.7251

CANADA OFFICE: 26162 30A Avenue, Aldergrove, BC V4W 2W5
Toll Free 1.888.870.0908 | Phone 604.607.0908 | Fax 604.607.0903

CHASSIS

MAKE/MODEL	FRONT AXLES	REAR AXLES	TOTAL WEIGHT	OVERALL LENGTH
MACK TERRAPRO	57,000 lbs 25,855 kg	71,998 lbs 32,658 kg	128,998 lbs 58,513 kg	54'5" 16.6 m

DIAGRAMS

OUTRIGGER EXTENSION

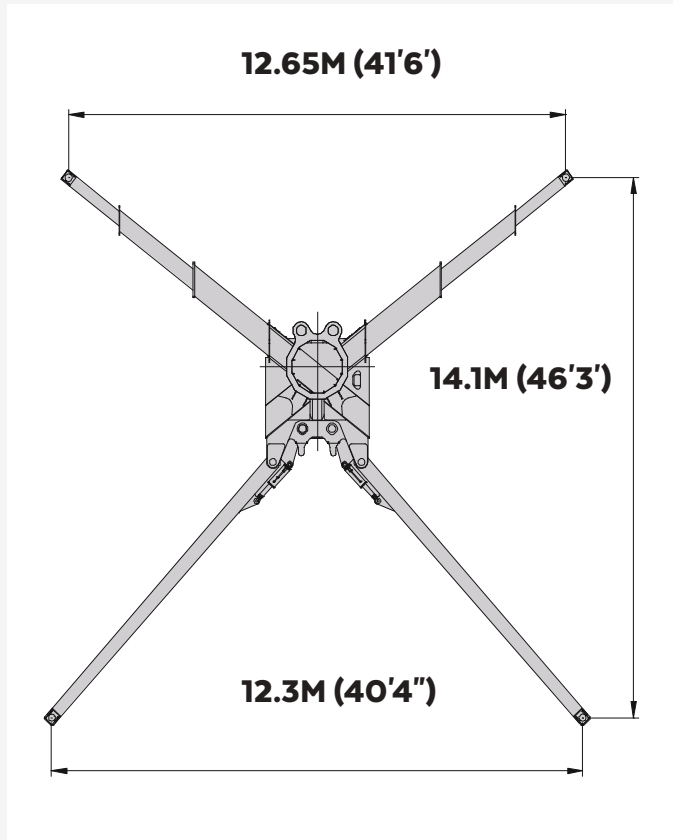

BOOM PUMP REACH

